

Specifications

Power Supply	24 VAC/VDC (19-24 V) 120 VAC (90-130 V)
Power Consumption	2.4 VA max (24 V power) 3 VA max (120 V power)
Setpoint Range	30, 50 & 100 mA, switch select
Voltage Range	Up to 600 VAC (monitored circuit)
Frequency Range	12-398 Hz (monitored circuit)
Output Rating	SPDT relay 1 A @ 125 VAC, 2 A @ 30 VDC resistive

Frequency of Monitored Circuit	Response Time
<17 Hz	<140 ms
17-32 Hz	<75 ms
>32 Hz	<45 ms

Time Delay	0-10 seconds plus response time
Isolation Voltage	1250 VAC, tested to 5 KV
Sensor Power Indication	Green LED = Power untripped
Output Tripped Status	Red LED = Output tripped
Dimensions	2.91"H x 3.86"W x 1.45"D (73.9 x 98.0 x 36.8 mm)
Sensing Aperture	0.75" (19.1 mm) inside diameter
Case	UL94 V-0 Flammability Rated
Environmental	-4 to 122°F (-20 to 50°C) 0-95% RH, Non-condensing Pollution Degree 2 Altitude to 6561 ft (2000 meters)
Listings	UL/cUL

Power Supply Notes

All low-current Ground-Fault Sensors are sensitive devices that require reasonable care in system design to avoid false trips caused by high electrical noise levels. Keep in mind that the best way to reduce noise in a system is to suppress it at its source.

1. Keep the sensor power isolated from noisy circuits.
2. Do not power the sensor with the same circuit that switches contactors or other high current, inductive loads.

System Grounding

Good design practice and code require that all AC power systems be grounded. AGV Series sensors are designed to work on grounded AC power systems. They will not operate properly on ungrounded systems.

Model Number Key

AGV 3 - SDT - 24U - LA - TR3

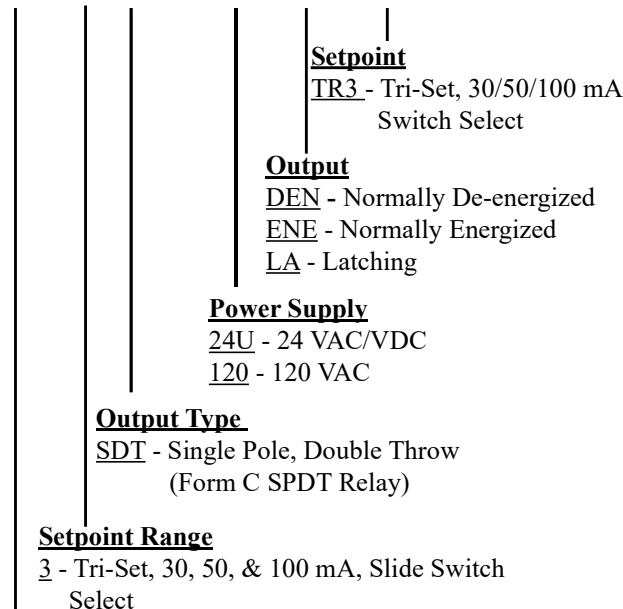

AGV Series Ground Fault

Know Your Power



Other NK Technologies Products Include:

AC & DC Current Transducers
AC & DC Current Operated Switches
1 ϕ & 3 ϕ Power Transducers
Current & Potential Transformers (CTs & PTs)



NK Technologies

3511 Charter Park Drive, San Jose, CA 95136
Phone: 800-959-4014 or 408-871-7510
Fax: 408-871-7515
sales@nktechnologies.com, www.nktechnologies.com



INSTRUCTIONS



AGV Series Ground Fault Sensors For VFD Driven Loads

Quick "How To" Guide

1. Pass all current carrying conductors include neutral return not ground return through sensor window.
2. Mount the sensor to a surface if needed.
3. Connect output & power wiring to unit.
 - A. Use 30-12 AWG copper conductors only rated for 60/75°C minimum.
 - B. Make sure power and load matches those shown on the sensor's label.
 - C. Set the desired trip point using the slide switch to choose 30, 50, or 100 mA setting.
4. Energize the monitored circuit. Add delay before the output changes state as required by turning pot clockwise, arrow pointing to the seconds added.
5. Test
 - A. Pressing the "TEST" button tests the sensor's internal circuits. **CAUTION: The output and any connected loads will switch! The LED shows red when a fault is detected or test button is pressed.**
 - B. For latching output models (-LA), momentarily shorting between the "reset" terminals will release the latched output contact. Do not apply voltage to the reset terminals.

Description

AGV Series sensors monitor all current carrying wires in single or three phase systems to detect ground faults. They provide a contact output that can operate relays, contactors or signal automation systems. The design goal is to provide a reliable detection with less spurious tripping.

Principal of Operation

Under normal conditions, the current in one wire of a two wire load is equal in strength but opposite in direction. The two wires together create cancel magnetic fields, a condition known as “Zero Sum Current”. If any current leaks to ground (Ground Fault), the two currents become unbalanced and there is a net resulting magnetic field. The AGV sensor detects this minute field and changes the output state. This concept extends to three phase systems such as 3 wire Delta (grounded) and also 3 or 4 wire Wye.

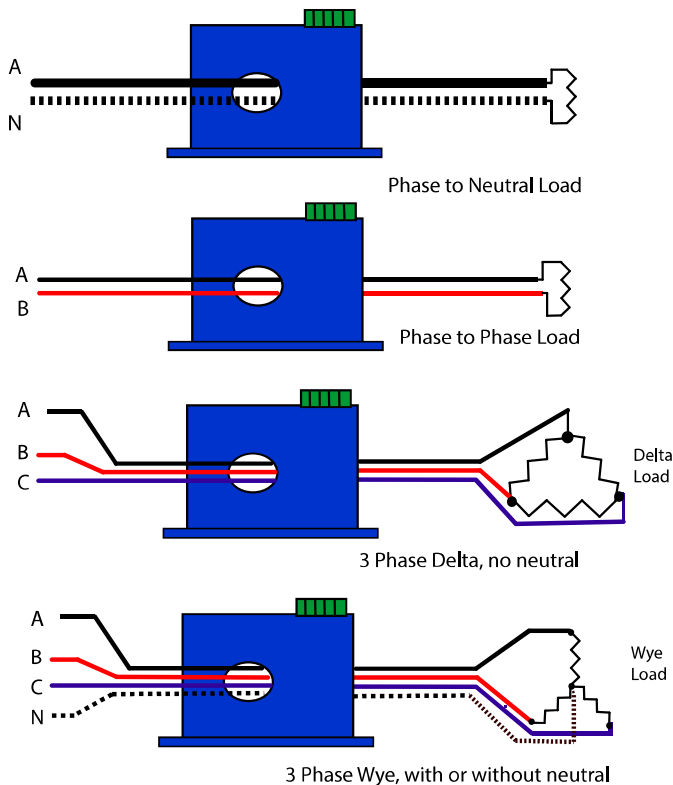

Installation & Wiring

AGV Series sensors work in the same environment as motors, contactors, heaters, pull-boxes, and other electrical enclosures. They can be mounted in any position or hung directly on wires with a wire tie. Just leave at least one inch distance between sensor and other magnetic devices. Run all current carrying conductors through the opening in the sensor. (See “Principal of Operation”) Be Sure all wires in a three phase system are oriented so current flows in the same direction.

Wiring to unit

Use 30-12 AWG copper wire and tighten terminals to 5-7 inch-pounds torque. See Diagram.

Power

Connect power wiring to Terminals 1&2. Be sure that the power supply matches the power supply limits on the sensor label.

Output

Connect output wiring to Terminals 3&4 (NC) or 4&5 (NO). Reset Switch (Latching Models) Terminals 6&7

Operation

AGV Series Latching Ground fault sensors operate in one of two states: Reset or Latched. If control power is removed, the sensor remains in it’s last state (latched or reset).

Reset

The sensor has not detected a fault and the output is in the “normal” position.

Latched

Upon detecting a fault or when the TEST switch is pressed, the output will switch (NO 4&5 closes and NC 3&4 opens), and “latches”. The output will remain latched until the ground fault is removed and the output is reset by a momentary dry contact on Terminals 6&7.

With **DEN** type models, the NO contact (4&5) closes on a fault and the NC (3&4) contact opens.

With **ENE** type models, the NO contact (4&5) closes when power is applied to the sensor, opens on a fault and the NC (3&4) contact opens when power is applied, and closes on a fault. The sensor contacts also revert to “shelf state” when power is removed from the **ENE** type models.

Testing

To test operation, gently press the TEST button. This simulates a fault and tests the internal switching circuits. After the test is complete, reset the sensor with a momentary dry contact on Terminals 6&7. **CAUTION: Any circuit connected to the sensor will be operated. Do not apply voltage to the reset terminals.**

Connect a momentary dry contact to the reset terminals (6&7). Limit wire run to 200’ of 18 AWG or larger wire.

Momentary Reset

The sensor will not work properly if the reset terminals are closed (shorted) continuously. Only close the reset terminals momentarily.

Parallel Reset Connection

Multiple sensors may be connected to the same reset switch in parallel. Only the sensors that have detected a fault and have latched will be reset. A sensor will not reset unless the fault has dropped below setpoint.

Monitored Circuit

Feed the wires carrying the monitored circuit current through the sensing aperture. The same sensor can monitor a single phase (hot and neutral), two phases (two hot) or three phase load up to 600 VAC. If the monitored load uses the neutral, it must pass through the aperture. The bond or ground wire should never be included.

Output table

Normally Energized Models(-ENE Option)

Protection from faults and control power loss.

	Control Power Applied		
	No Power	No Fault	Fault
N.C. Normally Closed	closed	open	closed
N.O. Normally Open	open	closed	open

Normally De-energized Models(-DEN Option)

Protection from faults.

	Control Power Applied		
	No Power	No Fault	Fault
N.C. Normally Closed	closed	closed	open
N.O. Normally Open	open	open	closed

Latching Models (-LA Option) from factory power up initially in the reset (normal) mode. If there is a fault condition or the test button is pushed, the output contacts will change state and latch. The output will remain latched regardless of whether the fault is cleared or control power is removed. To reset the output apply a momentary contact across “reset” terminals.

Typical Installations

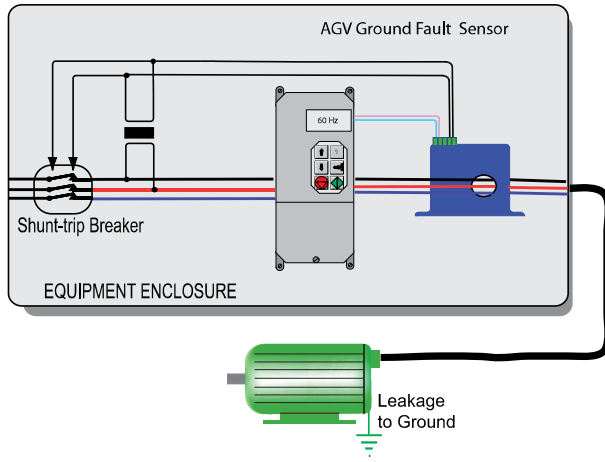

The AGV series ground fault detector was purposely designed to allow the protection of a load driven with a variable frequency drive to sense a fault to earth low enough to keep the equipment from being damaged but also to protect the workers using the equipment from electrocution. They will also work in applications where the frequency is stable.

The AGV sensor can be set to trip with a fault detected of 30, 50, or 100 mA. There is also a 0-10 second time delay which is adjusted by turning the potentiometer from the zero clockwise to 10 seconds as indicated on the label.

When the auto-reset type sensor is installed on the load side of a drive, between the motor and the controller the sensor contact which is open when the sensor is powered (NO 4&5 with -DEN contact action, NC 3&4 with -ENE contact action) is most often used to energize the operating solenoid of a shunt trip breaker. The drawing to the left illustrates a way these two components connect to work as a circuit disconnect. Once a fault is detected and the breaker has opened to de-energize the monitored circuit the fault goes away and the sensor resets to the original condition. The breaker handle acts as the reset to re-energize the load after the fault has been alleviated.

When the latching sensor is installed on the load side of a drive, between the motor and the controller the sensor contact the normally closed contact (3&4) is most often used to energize the operating coil of a contactor. The drawing to the left illustrates a way these two components connect to work as a circuit disconnect.

Once a fault is detected and the sensor contact opens to de-energize the contactor coil, which opens the contactor contacts. The contacts stay open until an externally mounted momentary pushbutton is closed across terminals 6 and 7. This resets the sensor output contacts so the monitored motor can be restarted.

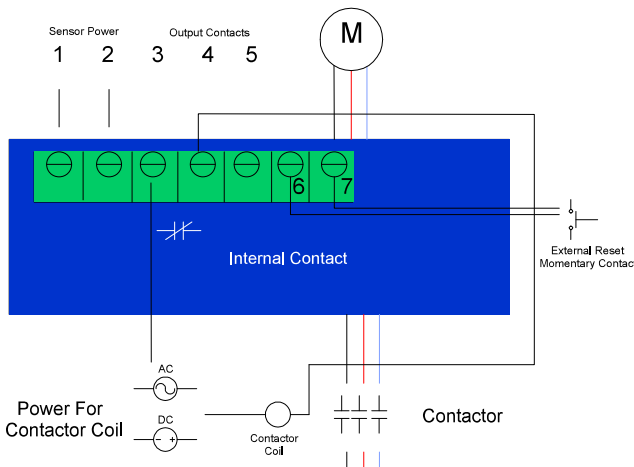
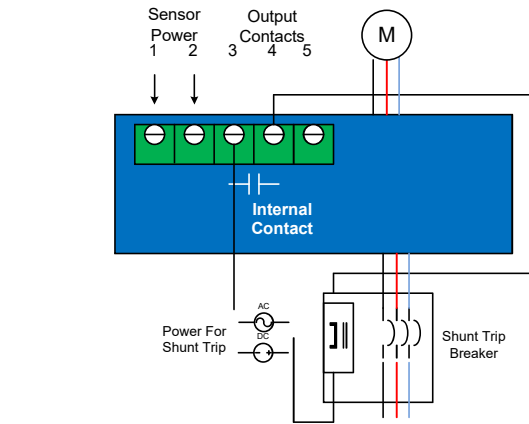

Trouble Shooting

1. During motor start, there may be an excessive amount of current loss due to capacitance leakage. This is shown as less current being returned to the source in the same manner as loss to ground. Field conditions will vary. *Adjust the time delay to allow the sensor output to remain in the "no fault" condition during this period of current loss.*
2. Longer runs of submersible pump cable or heat trace cable may create conditions with capacitance leakage between the two parallel conductors. This occurs constantly and the time delay will not keep the sensor from tripping. *The solution is to raise the trip point.*
3. Only the current carrying conductors pass through the sensing aperture. If using shielded cable, pass the shield through the sensor and then loop back to bond to earth on the line side of the sensor.
4. VFDs can produce quantities of electromagnetic noise, so it is recommended to allow as much space between the drive and the sensor. *This condition varies greatly between drive manufacturers and drive size, so spacing is a field installation variant.*
5. Latching output sensors are reset by closing a contact between terminals 6 and 7. While usually accomplished with a pushbutton, *a solid state transistor can also be used.* The sensor shows a (+) and (-) on the label, and this is only important if a solid state switching arrangement is used. No external voltage source is used.