

## Specifications

Power Supply	24 VAC/VDC (18-28V)
Power Consumption	160 mA
Output Switch	Isolated solid-state switch
Output Rating	1 A @ 240 VAC (general use)
Response Time	500 ms 5% over setpoint 200 ms 50% over setpoint 150 ms 100% over setpoint
Hysteresis	5%
Setpoint Range	ASD1: 1-50 A (adjustable) ASD2: 4-200 A (adjustable)
Setpoint Adjustment	Single turn potentiometer Setpoint displayed on sensor
Accuracy	+/-1%, FS
Isolation Voltage	Tested to 1480 VAC
Frequency Range	40-100 Hz
Sensing Aperture	0.75" (19.1 mm)
Operating Environmental	-4 to 122°F (-20 to 50°C) Surrounding air 0-95% RH, Non-condensing Pollution Degree 2 Altitude to 6561 ft (2000 meters)
Listings	UL/cUL, CE

### For products intended for the EU market, the following is applicable to the CE compliance of the product:

The ASD Series may comply with EN 61010-1 CAT III 300 V max line-to-neutral measurement category. If insulated cable is used for the primary circuit, the voltage rating of the measurement category can be improved according to the characteristics given by the cable manufacturer. Use twisted pair for all connections.

#### 24 Volt AC or DC Power Supply

Fuse at 5 amps maximum

Overvoltage Category I

#### Warning! Risk of danger

Safe operation can only be guaranteed if the sensor is used for the purpose it was designed for and within limits of the technical specifications. When this symbol is used, it means you must consult all documentation to understand the nature of potential hazards and the action required to avoid them.



#### Warning! Risk of shock

When operating the sensor certain parts may carry hazardous live voltage (e.g. primary conductors, power supply). The sensor should not be put into operation if the installation is not complete.



## Model Number Key

### ASD 1- NOAC - 24U - FL

#### CASE STYLE:

FL - Solid-Core

#### POWER SUPPLY:

24U - 24 VAC/VDC

#### OUTPUT:

NOAC - Normally Open solid-state contact,  
1A @ 240 VAC maximum

NCAC - Normally Closed solid-state contact,  
1A @ 240 VAC maximum

#### RANGE:

1 - 1-50 Amps AC

2 - 4-200 Amps AC

#### SENSOR TYPE:

ASD - AC current operated switch, LED display of the adjustable trip point

## Description

The ASD series current relays are externally powered AC current sensors which utilize a revolutionary method to set the point where the primary current actuates the solid-state output. By turning a potentiometer, the set point will be changed. An LED display on the top of the sensor shows the value in amps where the contact will change. Models with contact set point ranges of 1-50 or 4-200 amps can be selected.

## Know Your Power



## NK Technologies

3511 Charter Park Drive, San Jose, CA 95136

Phone: 800-959-4014 or 408-871-7510

Fax: 408-871-7515

sales@nktechnologies.com, www.nktechnologies.com



# INSTRUCTIONS



## ASD SERIES AC Current Operated Relay Single Range with Solid State Output

## Quick "How To" Guide

1. Mount the sensor to a suitable surface if required.
2. Run the wire to be monitored through aperture.
3. Connect output wiring.
  - A. Use 30-12 AWG copper conductors only.
  - B. Ensure the power supply voltage matches the model you are installing.
  - C. Energize the power to the sensor.
4. Adjust Setpoint.
  - A. LED will display the RMS value of AC current which will cause the output to change state.
  - B. Turn the potentiometer until your target current value is displayed.
  - C. The display will flash when current exceeds the setpoint to indicate the output has changed state: NO has closed, NC has opened.

## Installation

ASD Series are externally powered, current-operated switches or relays. The contact trips when sensed current level exceeds the adjusted setpoint. The normally open contact closes on current rise, the normally closed contact opens on current rise. The output resets when current falls 5% below the set point.

ASD sensors can be located in the same environment as motors, contactors, heaters, pull-boxes, and other electrical enclosures. The sensor can be installed in any position using the screw holes in the mounting tabs, or hung directly on wires using a wire tie. Ensure at least one inch clearance exists between sensor and other magnetic devices.

Run wire to be monitored through aperture (opening) in the sensor. The direction that the wire passes through the opening is not important.

Connect the output contact to the load to be switched, being sure that the load does not exceed the capacity of the output contact. The contact is solid-state, and will be able to control any AC circuit from 2 to 240 VAC, and up to one amp at any voltage.

Connect the power supply voltage to the appropriate terminals, being sure that the supplied power matches the sensor designed voltage. Energize the sensor power supply.

Initially the LED display will show the range maximum. Set the desired trip point by turning the potentiometer counter-clockwise. The display will show the amount of AC current needed to trip the output.

A normally open contact will close at this setpoint, and a normally closed contact will open.

## Setpoint Adjustment

ASD Series setpoint is adjusted using a single turn potentiometer. The LED three digit display will show the amount of current needed to cause the output to change state. The setpoint adjustment can be done before the monitored load is energized, improving the safety of the installation. The sensor must be powered to operate the display.

The adjustment is made by turning the screw clockwise to raise the setpoint, counter clockwise to decrease the setpoint. The ASD1 models can be set to trip at any current level from one to 50 amps. The ASD2 or models can be set to trip between four and 200 amps.

The display will flash when current exceeds the setpoint.

## Output Wiring

Connect control or monitoring wires to the sensor. Use 30-12 AWG copper wire and tighten terminals to 5-7 inch-pounds torque. Be sure the output load does not exceed the switch rating.

**CAUTION** Incandescent lamps can have “Cold Filament Inrush” current of up to 10 times their rated amperage. Use caution when switching lamps with solid-state “contacts”.

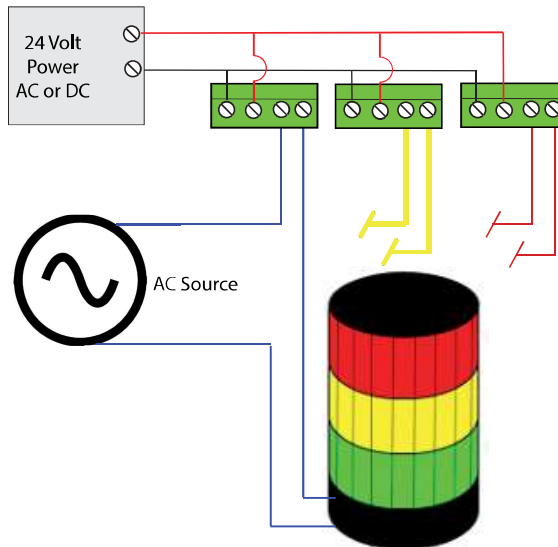
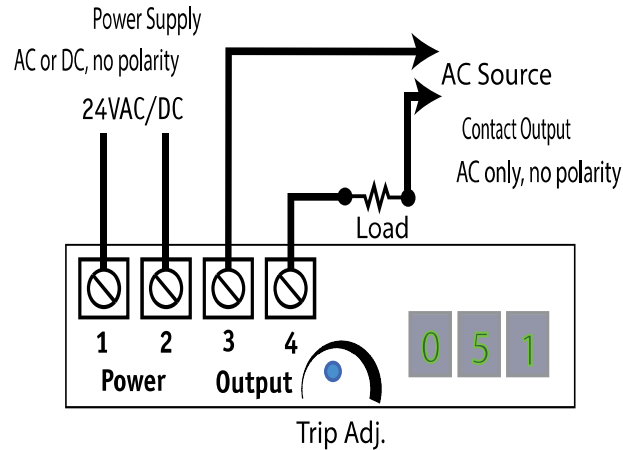

Example of three ASD switches powered from one supply, so when current through one of the switches reaches setpoint the output closes to energize one level of the stack light.

## Trouble Shooting

### 1. Sensor is always tripped

- The setpoint may be too low. *Turn the potentiometer CW to a higher setting.*
- Switch has been overloaded and contacts are burned out. *Check the output load, remembering to include inrush on inductive loads (coils, motors, ballasts).*

### 2. Sensor will not trip

- The setpoint may be too high. *Turn the potentiometer CCW to a lower value.*
- Monitored current is below minimum required. *This sensor can be set to trip at a minimum of 1 amp (ASD1) or 4 amps (ASD2). Loop the conductor through the sensing window twice to reduce the trip point to 0.5 (or 2) amps.*
- Switch has been overloaded and “contacts” are burned out. *Check the output load, remembering to include inrush on inductive loads (coils, motors, ballasts).*
- Current is DC or of a lower frequency than 40 hertz. *The sensor can be used to monitor 40-100 hertz AC current only.*
- There is more than one phase through the aperture. *Thread only one current carrying conductor through the aperture, or multiple conductors connected to the same phase. Do not pass the grounding wire through the sensor. The neutral can be monitored if the load is single phase, but do not install both hot and neutral.*